

# Queens College Technology Enhanced Classroom (TEC) Specifications

9/2008

## Instructor's Station

- All Technology Enhanced Classrooms (TEC) must include an appropriately placed instructor station. It must allow for the following:
  - Placement of a dedicated PC, Sympodium, keyboard and mouse, as well as space for a laptop. The laptop and dedicated PC keyboard area should be at a comfortable standing height. The CPU should be housed below the work surface.
  - Allowance for A/V gear such as VCRs, audio controls, and projector connections.
  - Allotment of space for instructors to place paper handouts and read from paper notes for use during a class. It should include lighting for this task, and this area should be at a comfortable standing height.
  - The ability to hardwire the station.
  - A door to secure the gear below the work surface.
  - A panel with terminations for VGA or DVI, Network (RJ45), power, audio etc. that would allow the instructor's station to be quickly and easily disconnected and moved to another location through the use of standard "patch" cables.
- Currently the standard instructor station is:
  - Spectrum Industries Media Manager V2 with Extron control cutouts.

## Room Layout

- Instructor's station location should be at the opposite side of the room from the door when possible.
- Projection screens locations are determined by:
  - Instructor's station location. Screen should be on the same side of the room.
  - Visual obstructions to the student stations.
  - Direction student stations face. Students should not be required to turn in order to see the instructor or the projection.
- White board location should be close to the instructor's station, visible to all of the student stations and not blocked by the projection screen. There should be at least 16 square feet of white board space near the projection screen and the instructor's station for instructor's use during class. A second whiteboard should be located in the room for information beyond the instructor's class notes such as lab schedule etc.
- Tack boards should be located in the following places:
  - Near the instructor's station for notes for the instructor such as computer passwords etc.
  - Near the exit of the room for postings to students.
- Space should be allotted at the front of the room for an instructor's station with a minimum of 3 feet of space behind, and a minimum of 2 feet of space in front of the instructor's station.

- All applicable ADA guidelines must be followed.
- All applicable fire and safety codes must be followed.

## **Electrical / Networking**

- All electrical panels in labs must have keyed locks.
- Light fixtures closest to the projection screen must be on a separate switch. Control of these fixtures must be available near the instructor's station as well as near the door.
- The current standard is 3 computers per 15-amp circuit.
- One outlet must be installed in an appropriate location in the ceiling to provide power to the projector.
- One outlet must provide power for the instructor's station. It should have its own 15-amp circuit.
- Three jacks for the instructor's station as well as a telephone must be provided.
- All data cable and components should be from the same manufacturer. Lucent Gigaspeed is preferred. The installer should be trained and authorized by the manufacturer and provide the manufacturer's maximum performance warranty.
- O.C.T. will specify the type of network hardware (hubs or switches) if any are needed. Please note that prices and equipment specifications change constantly and each new or renovated facility needs to be assessed individually.

## **Technology**

- Smart Sympodiums are considered standard equipment for TECs. Departments should be asked if it is a piece of equipment that will be functional for their use of the TEC. If not, it should not be included.
- Static projection screens are preferred and should not obstruct the whiteboard.
- Laptops brought in by instructors must be able to use the symposium and keyboard and mouse.
- Standard equipment includes but is not limited to:
  - NEC Projector (model TBD on an individual basis) and a screen
  - Extron control system, amplifier and speakers
  - DVD/VCR
  - Desktop computer
  - Connections for a laptop, and a media player
- OCT Media Services will provide specifications for the A/V system. Please note that prices and equipment specifications change constantly and each new or renovated facility needs to be assessed individually

## **Facilities**

- No Chalkboards are to be installed in any TEC. Whiteboards using erasable markers are an appropriate substitute.
- Any rooms with carpeting must use static free carpeting.

## **Specifications and Plans**

- All facilities should have CAD drawings provided showing changes to existing facilities as well as furniture and equipment placement.
- All drawings should include a scale bar. This allows the drawings to be enlarged or reduced while retaining the ability to take rough measurements.
- Drawings should indicate the aisle widths as well as ADA compliance notes.
- Furniture models and other specifics need to be identified.

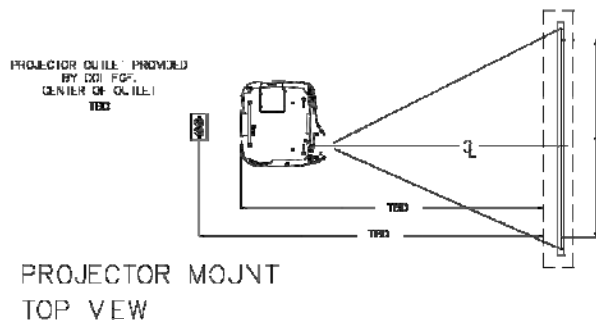
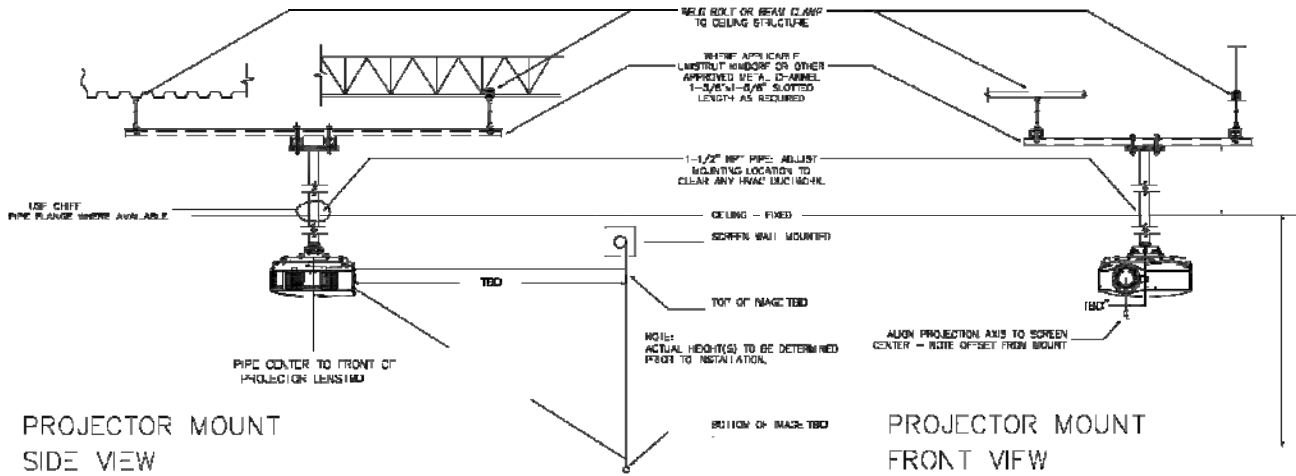

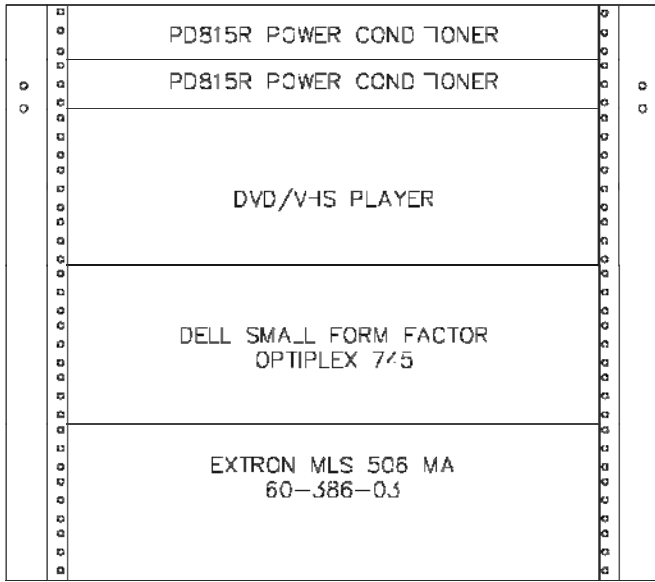

SECURITY SCREWS TO BE USED IN FIXATING THE RACK

